

GARN®

**MODELS: WHS-1000H
WHS-1000V**

OVERVIEW:

The GARN Wood Heating System (WHS) is a highly efficient direct-gasification cordwood burner that heats an integrated, large water volume, thermal storage tank. The GARN features several technical advantages over conventional wood burning equipment:

- **Low Emissions:** gasification is achieved with a unique, high-temperature, non-modulated batch burn process.
- **Simple:** combustion air to the fire is not modulated, so there are no motorized dampers or blowers that cycle on and off.
- **High Efficiency:** a large diameter, high surface area, 5-pass heat exchanger ensures efficient heat transfer over the life of the unit.
- **Safe:** cool combustion air circulates around the combustion door keeping it cool to the touch.

MECHANICAL & ELECTRICAL SPECS:

Hot Water Supply Connection.....	1-1/2" FPT
Hot Water Return Connection.....	1" MPT
Makeup Air Requirement (at sea level).....	450 CFM
Weight Empty.....	2,200 lbs
Weight Full.....	10,630 lbs
WaterStorageVolume.....	1015 Gallons
Flue.....	.6 inch, Class A 2100 °F
Maximum Flue Discharge Temperature.....	500 °F
Front and Back Heads.....	3/16" grit-blasted mild steel
Tank and Other Parts.....	3/16" grit blasted mild steel
Electrical requirements.....	15 AMP, 120VAC

FLUE SPECIFICATIONS:

Two configurations of the GARN WHS-1000 are available: a Vertical Exhaust configuration (WHS-1000V) and a Horizontal Exhaust configuration. (WHS-1000H) The horizontal configuration must use DuraTech® All-Fuel Class A 2100F flue (For Canadian installations, DuraTech® Canada must be used). The vertical configuration comes with a universal flue connection so any manufacturer's insulated Class A 2100F rated flue with a 8 inch outer diameter and 6 inch inner diameter is acceptable.

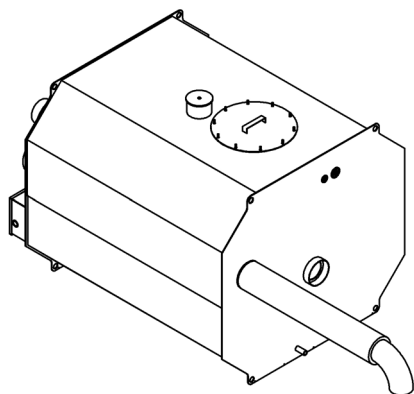

WHS-1000H
(Horizontal Exhaust Configuration)

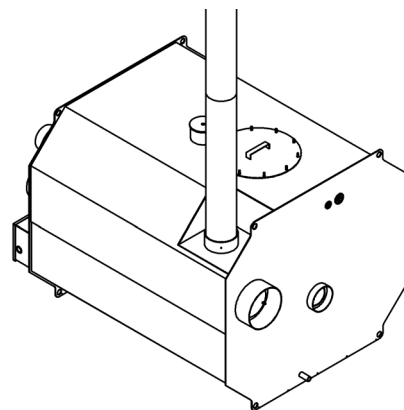

WHS-1000V
(Vertical Exhaust Configuration)

FUEL:

GARN wood heating systems can burn cord wood, slab wood, dense wood briquettes, air-dried corn on the cob, pallets and other scrap wood. Emissions information is listed and certified for cordwood fuel only.

OPERATION:

Periodic firings are used to bring the unit's large water volume up to approximately 195 °F. Hot water can be drawn from storage and delivered to the connected building's heating system during firing and for hours after firing is complete. When the water temperature in the thermal storage drops below the temperature required by the connected heating system, the GARN WHS is re-loaded and re-fired and the process is repeated.

- **The heat output rate from the thermal storage to the connected heating system is independent of the firing rate.** See the "Thermal Performance" section for further explanation and more information.

SAFETY LISTINGS:

GARN equipment is certified safe in the United States and Canada by Warnock Hersey / Intertek testing labs.



ANSI/UL-391
UL-726
CAN/USA B366.1-11v

TEMPERATURE SENSORS (INCLUDED):

The GARN WHS Digital Controller (4) reads and displays temperatures from the following temperature sensors:

Sensor Acronym	Description
TST	Thermal Storage Temperature
FGT	Flue Gas Temperature
HWS	Hot Water Supply
HWR	Hot Water Return
OT	Outdoor Air Temperature

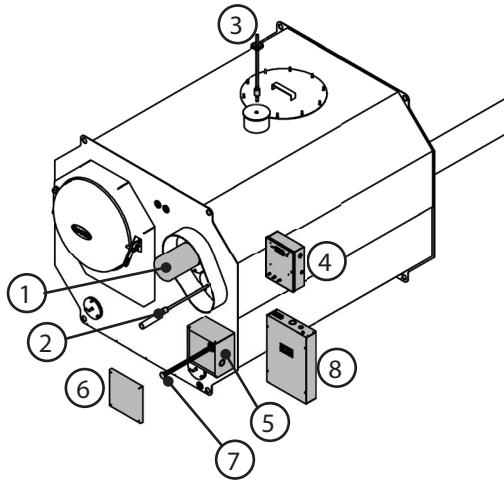

ELECTRONICS AND CONTROLS (INCLUDED):

- ① **Blower Motor:** The blower motor is connect to a blower wheel inside the GARN's custom designed blower housing. The blower motor produces an induced draft on the combustion chamber so that backdrafting is minimized when the combustion door is opened.
- ② **Flue Gas Temperature Sensor:** Monitors flue gas temperature.
- ③ **Sensor Stem:** The sensor stem has two functions: to provide a Low Water CutOff (LWCO) signal and to monitor the thermal storage tank water temperature (TST).
- ④ **Digital Controller:** Starts the blower motor when a fire is started. Stops the blower motor when the fire has burned all of the wood. Uses digital feedback from the flue gas temperature sensor and sensor stem to ensure safe and efficient operation.

ELECTRIC HEATING PACKAGE (OPTIONAL ACCESSORY):

The Electric Heating Package turns the GARN unit into an electric heating system. The Digital Controller (4) can interface with the utility's off-peak/discounted rate programs. The following electronics and controls components are optional and must be purchased in addition to the standard GARN package:

- ⑤ **Electric Element Box:** A UL® listed box bolts to the front of the GARN unit to protect the electric elements.
- ⑥ **Electric Element Box Cover:** A cover for the Electric Element Box (5).
- ⑦ **Electric Element(s):** A total of 3, 6, or 9 electric elements (5.5 kW at 240 VAC each) thread into the flanges on the front of the GARN unit.
- ⑧ **Sequencer:** Turns the electric elements on one after another in sequence to provide a smooth and gradual power-up.

THERMAL PERFORMANCE:

Annual Efficiency Rating.....77% (HHV) / 83% (LHV)
 Firing Rate¹.....330,000 btuh
 Heat Delivered to Thermal Storage¹.....650,000 btu
 Heat Output Rate.....See Table 1 Below

¹ Based on a single fuel charge of 120 lbs red oak with 22% moisture content. Values will vary based on fuel species, moisture content, and unit elevation.

There is a fundamental difference between the *firing rate* and *output rate* (building heat load).

Firing (Heat Input) Rate: the rate at which heat is added to the thermal storage from the process of wood combustion and the efficiency of the heat exchanger.

Heat Output Rate: the rate at which heat is removed from the thermal storage and delivered to the connected heating system.

With conventional wood heating systems, the equipment attempts to match the firing rate to the output rate. With the GARN WHS, the firing rate is nearly constant during the wood combustion process while the output rate varies. The operator continues to add wood until the thermal storage temperature is up to 195°F. Table 1 illustrates how long the GARN WHS thermal storage will last before the need to re-fire. For example, with a heat load of 50,000 btuh and a lower system operating temperature of 125°F, re-firing is required every 11.1 hours.

		Lowest System Operating Temperature [°F]		
		110	125	145
Output Rate (Heat Load) [BTUH]	180,000	3.8	3.1	2.2
	150,000	4.6	3.8	2.7
	100,000	6.8	5.6	4.0
	75,000	9.0	7.4	5.3
	60,000	11.2	9.3	6.6
	50,000	13.4	11.1	7.9
	40,000	16.7	13.7	9.8
	30,000	22.0	18.1	12.9
20,000	32.3	26.6	19.0	

Table 1: Time Between Firings (hours) Based on Heat Load and System Operating Temp. (assumes thermal storage temperature starts at 195°F)

EMISSIONS:

Particulate emissions and heating efficiency Conforms to: ASTM E2618-2009

Important: this appliance's emission ratings are based on burning seasoned cordwood fuel only. Failure to operate this appliance as directed may result in violation of air quality regulations and subject the operator to enforcement actions including fines and/or removal orders.

Particulate Emissions Rates:

0.19	lb/mmbtu output
0.15	lb/mmbtu input
3.69	g/hr (year round)
4.77	g/hr (heating season)

WATER TREATMENT AND CHEMISTRY:

Because the GARN WHS has a large thermal storage volume, the quality and chemical treatment of the water used is the most essential element to ensure the equipment's longevity and efficient operation. A water treatment program is included with the purchase of a GARN WHS. The water treatment program includes the following at NO COST:

1. The initial chemical required to test and treat the fill water.
2. Routine (semi-annual) analysis of the tank water.

There are three main components to water treatment program:

- **Sample:** using the included water bottle, sample the fill water (if initially filling the unit) or the water from the tank.
- **Test and Analyze:** the sample is sent out for analysis. A report from the lab is returned which details the outcome of the lab analysis.
- **Treat:** Based on results of the lab analysis add or maintain chemical as needed.

Fill water must be analyzed before the unit is initially filled and a water sample must also be taken twice per year (every 6 months). For more information, consult the *GARN WHS Owner's Manual*, available online at www.garn.com

INSULATION:

The GARN WHS must be insulated on site. Non-combustible materials must be used in the construction of the insulation enclosure. The following types of insulation may be used: Vermiculite or perlite, dense-pack blown in non-binder fiberglass or rock wool, unfaced glass fiber batts, unfaced rock wool batts.

CLEARANCE TO COMBUSTIBLES:

All GARN® WHS equipment must be placed in a sheltered, enclosed space (heated or unheated). Clearance to combustibles must be no less than 2" from the sides and back and 60" in front.

UNIT DIMENSIONS:

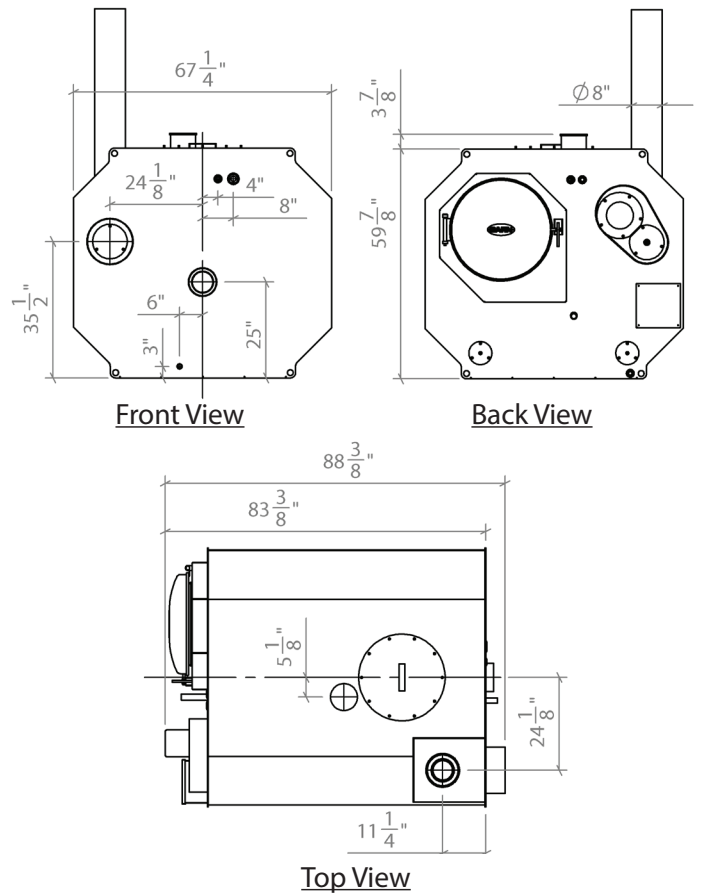

CONNECTIONS AND NOMENCLATURE:

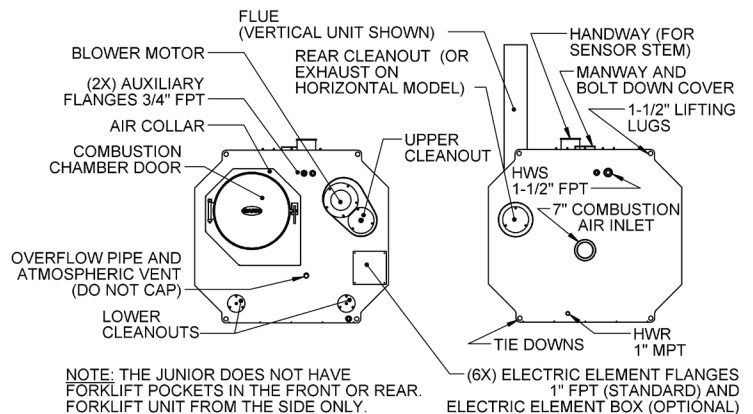

WARRANTY:

The GARN WHS comes with a 5 year warranty. For specifics related to the warranty, consult the *GARN WHS Owner's Manual*, available online at www.garn.com

DECTRA CORPORATION
St. Anthony, MN 55418
612-326-1100

